

**Ferrolì**

Lista Pezzi / Spare Parts / Ersatzsteile  
List Onderdelen / Liste Pieces Detaches / Lista Piezas De Repuesto

**DOMUSFIRE F17 L40DA00A00 Vers.00**

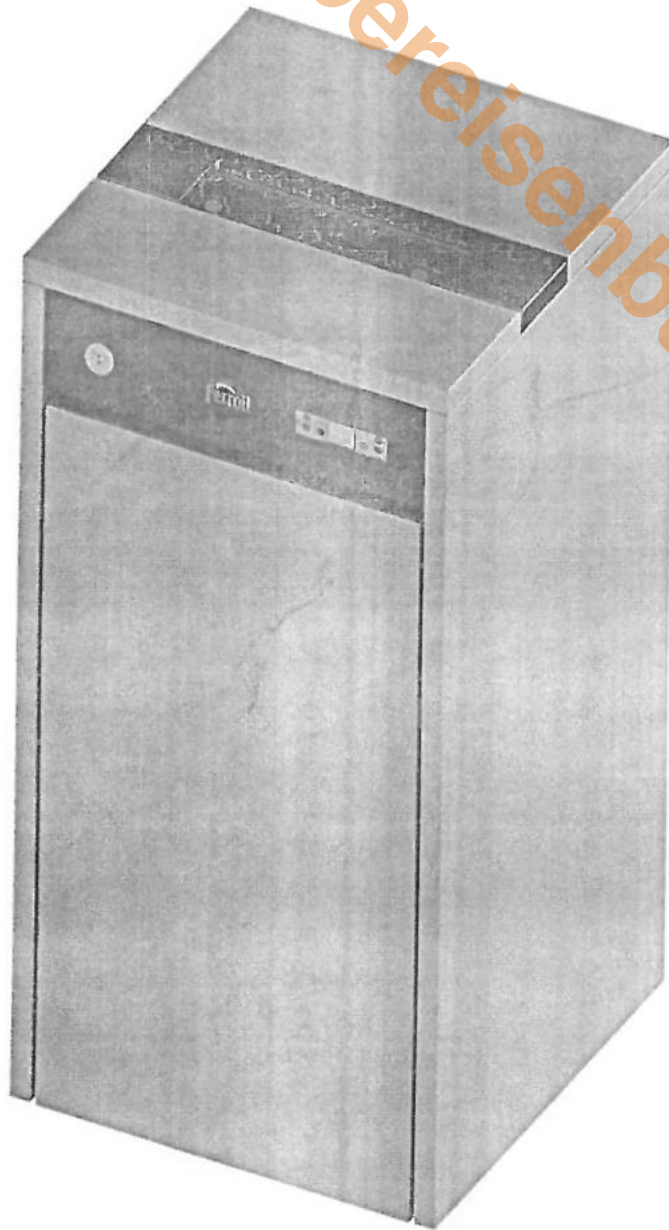

Codice Prodotto-Vers.	Data Validità	Mercato
L40DA00A00	01/06/2013	WS

La ditta si riserva di apportare in qualsiasi momento, senza preavviso alcuno, eventuali modifiche tecniche od estetiche ai prodotti.  
U.T. COLA - Diritti riservati - Riproduzione vietata



COLA s.r.l. - Viale del Lavoro 7/9 - 37040 Arcole (VR) Italy - Tel. 045.7635780 - 045.6144043  
Cod. Fisc. - P.IVA e Iscr. Reg. Impr. 02990180230 - Capitale Sociale Euro 52.000,00 i.v. R.E.A. VR-301021 - Socio Unico  
Fax Amministrazione 045.6100317 - Fax Commerciale 045.7639032 - Fax Assistenza 045.7639030 - Fax Logistica 045.6144048  
email: info@anselmocola.com - on line: www.colastufa.com

"direzione e coordinamento della Ferrolì spa"

La quantità indicata è quella presente fisicamente nella stufa / The quantity indicated is physically present in the stove / Die angegebene Menge physisch im Ofen vorhanden ist / La quantité indiquée est physiquement présent dans le poêle / La cantidad indicada es físicamente presente en la estufa

**DOMUSFIRE F17 L40DA00A00 Vers.00**

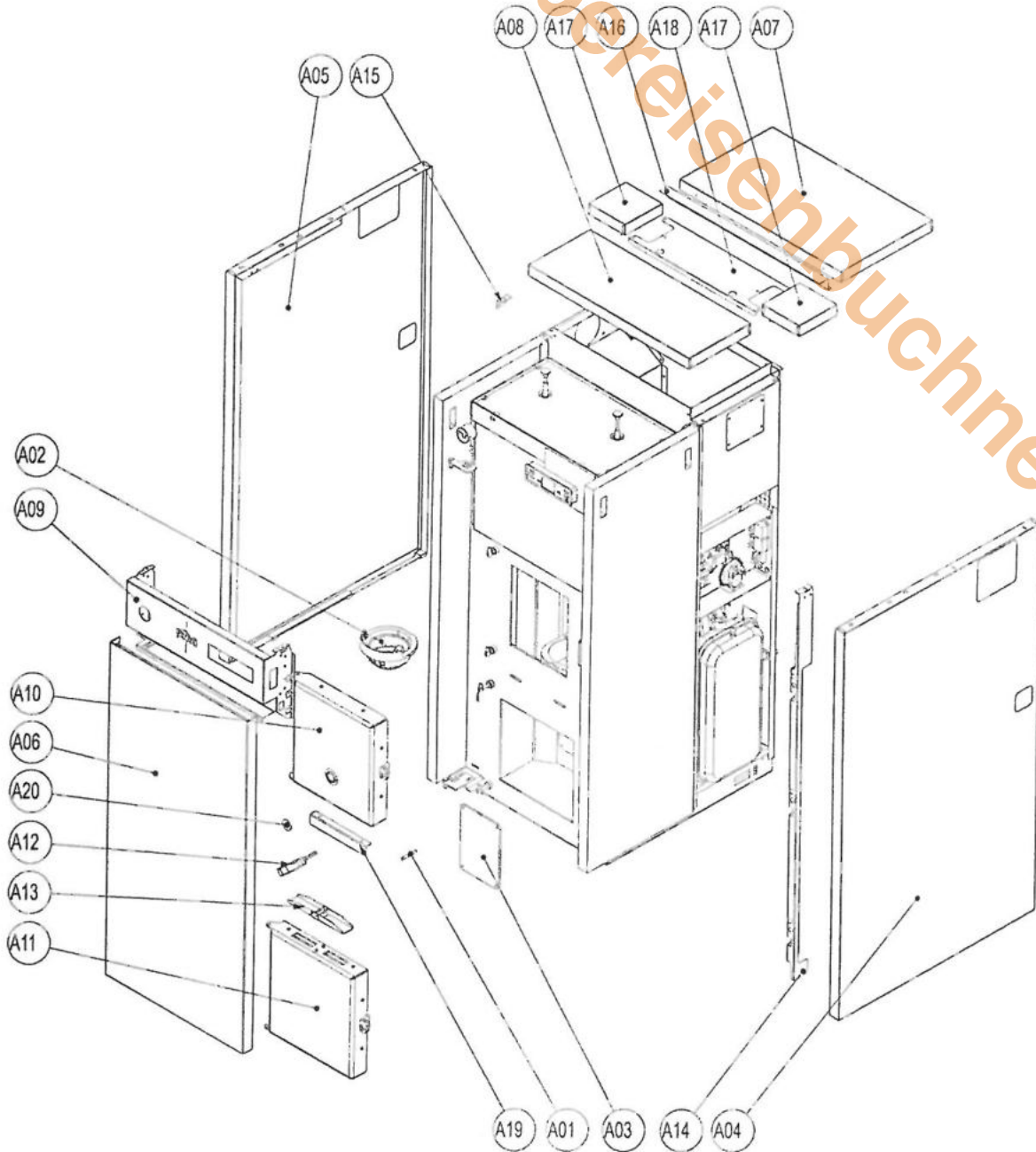

La quantità indicata è quella presente fisicamente nella stufa / The quantity indicated is physically present in the stove / Die angegebene Menge physisch im Ofen vorhanden ist / La quantité indiquée est physiquement présent dans le poêle / La cantidad indicada es físicamente presente en la estufa

**DOMUSFIRE F17 L40DA00A00 Vers.00**

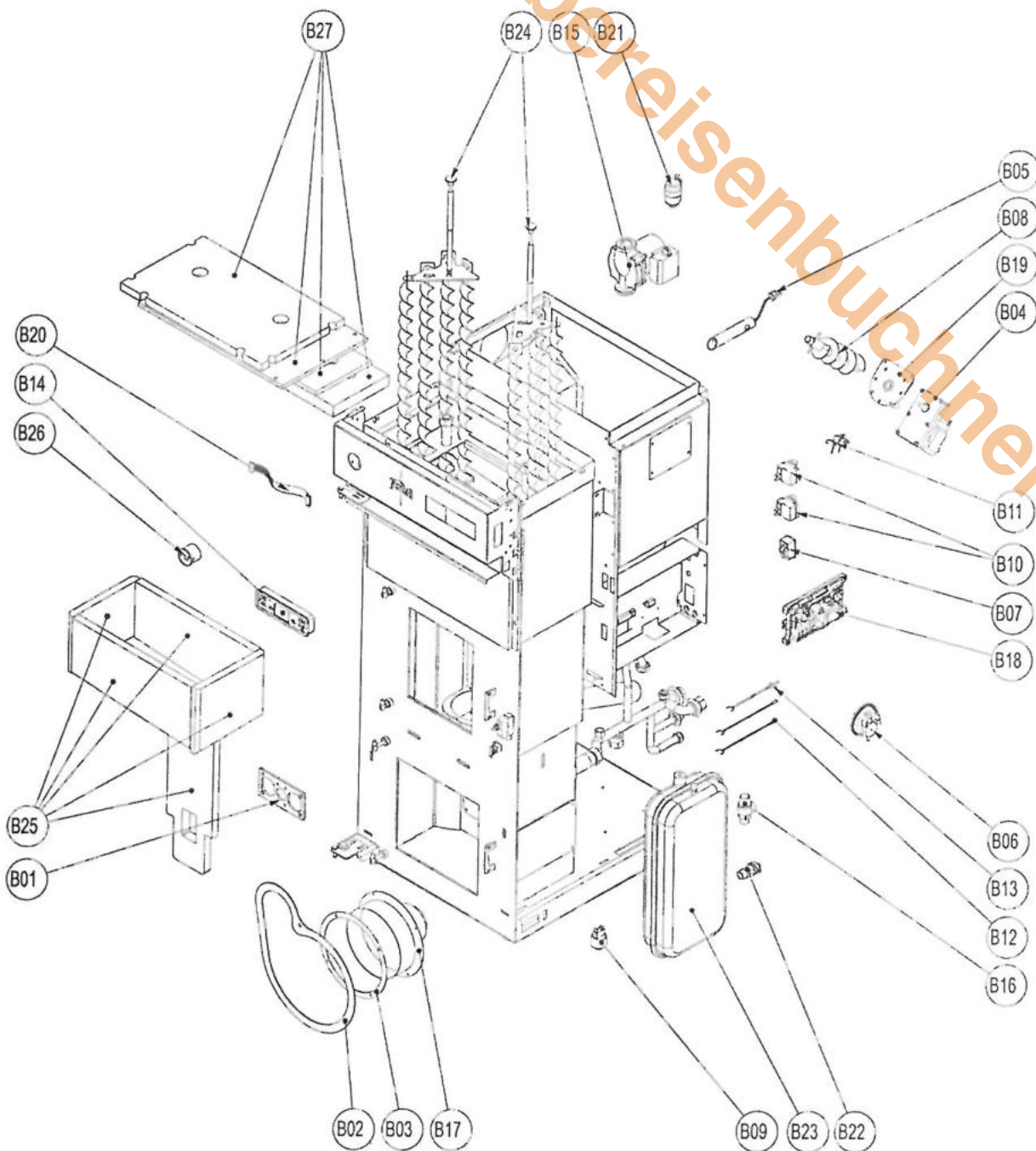

La quantità indicata è quella presente fisicamente nella stufa / The quantity indicated is physically present in the stove / Die angegebene Menge physisch im Ofen vorhanden ist / La quantité indiquée est physiquement présent dans le poêle / La cantidad indicada es físicamente presente en la estufa

# DOMUSFIRE F17 L40DA00A00 Vers.00

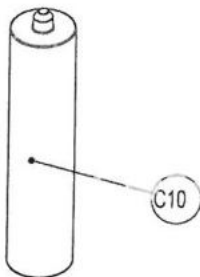
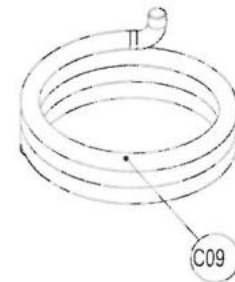
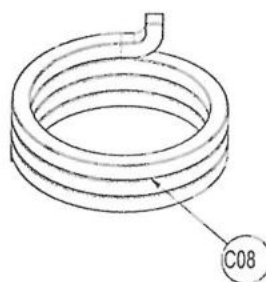
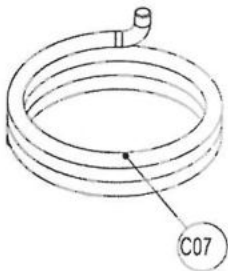
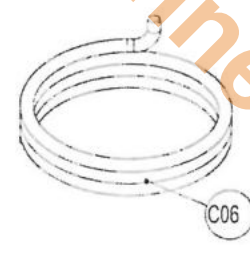
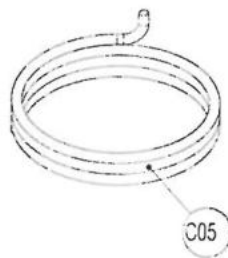
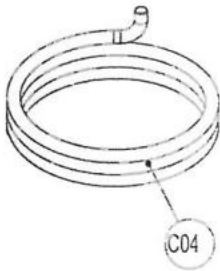
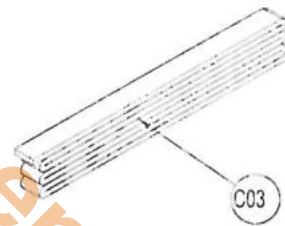
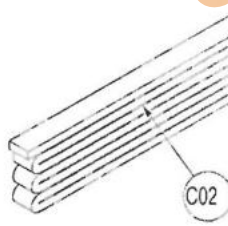
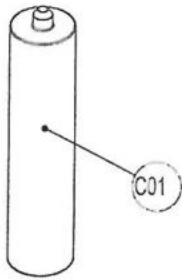

## DOMUSFIRE F17 L40DA00A00 Vers.00

### LISTA PEZZI L40DA20A CALDAIA PELLETT DOMUSFIRE F17 RAL2003

POS.	CODICE	DESC.	QT.
A01	306601720	TUBO PRELIEVO ARIA VACUOSTATO	1
A02	31100010071	BRACERE PELLETS G.M.A	1
A03	365200670	GUARNIZIONE TAPPO ISPEZIONE	3
A04	30860572027	PANNELLO LAT.DX RAL2003	1
A05	30860573027	PANNELLO LAT.SX RAL2003	1
A06	36140038027	PORTA ESTERNA RAL 2003	1
A07	30620263027	COPERCHIO TRAMOGG.RAL2003	1
A08	599003430	COPER.ANT.CALDAIA ARANCIONE	1
A09	30380412195	SUPPORTO FRONT.NERO	1
A10	51510082191	PORTA ISPEZIONE NERO	1
A11	51530003191	PORTA CENERE NERO	1
A12	599001700	GR.RIC.CHIAVE DI MANOVRA PORTA	1
A13	599001780	GR.RIC.VALVOLA SICUREZZA	1
A14	35260421195	STAFFA X MAGNETE NERO	1
A15	35260428095	STAFFA FISS.PANN.LATER.SX NERO	1
A16	36720012095	MANIGLIA COP.TRAMOGG.NERO	1
A17	30620254095	COPERCHIO INTERM.NERO	1
A18	30980378095	LAM.BASE COP.INTERM.NERO	1
A19	599003190	STAFFA FINE CORSA VALVOLA CALD	1
A20	599003200	VETRINO SPIONCINO D.30	1
B01	365200410	GUARNIZIONE PORTAB.CAM.TERMO	2
B02	365200690	GUARNIZIONE CONVOGLIATORE	1
B03	365200710	GUARNIZIONE ESTRATT.-CONVOG.	1
B04	599000230	GR.RICAMBIO MOTORIDUTTORE 2RPM	1
B05	599000251	GR.RICAMBI RESIST+TUBO '08 D16	1
B06	599000260	GR.RICAMBIO PRESSOSTATO ARIA	1
B07	599000440	RIC.INTERR+PORTAFUS.CABL.	1
B08	599000450	GR.RIC.COCLEA CANALE	1
B09	599000550	GRUPPO RICAMBIO TRASDUTTORE	1
B10	599000630	GR RIC.TERMOSTATO SICUREZZA	2
B11	599001170	GR.RICAMBIO DEBIMETRO	1
B12	599001180	GR.RIC.SOND AMB-ACQ.MIC L=1500	2
B13	599001190	GR.RIC.SONDA FUMI MICR. L=1500	1
B14	599001230	RIC.PANN.CONS.COMAN.F047-IDRO	1
B15	599001330	GR.RIC.POMPA WILO RS 25/5 3VEL	1
B16	599001370	GR.RIC.VALV.SICUR.PRESS. 3 BAR	1
B17	599001530	GR.RIC.ESTR.F.EBM R2E180+TACH	1
B18	599001580	GR.RIC.SCHEDA MICRONOVA N025	1
B19	599001710	GR.RIC.FLANGIA FERMA MOTORID.	1
B20	599001750	GR.RIC.CAVO FLAT PIATTO L=1700	1
B21	599001830	GR.RIC.VALV SFIATO ARIA 3/8	1
B22	599002520	KIT RUBINETTO SCARICO	1
B23	599002570	KIT VASO ESPANSIONE 220*450	1
B24	599003040	TURBOLATORI CALDAIA	2
B25	599003050	VERMICULITE CALDAIA 15	1
B26	599003170	TERMOMANOMETRO D40 IMIT	1
B27	599003180	ISOLANTI COPERCHIO CALDAIA 15	1
C01	599001880	SIGILLANTE TEXFIRE 1100°	1
C08	599001950	TRECCIA QUADRA 14X14 POLARTEX	1
C10	599001970	SILICONE TERMORESISTENTE NERO	1
C11	599001980	TUBO SILIC. D.E. 8 - D.I 4,5	1